

DESCRIPTION

BLOWER:

- Plug-in, permanently lubricated motor - engineered for continuous operation
- Dynamically balanced centrifugal blower wheel for quiet, efficient performance
- Low RPM for quiet operation
- Resilient anti-vibration motor mounts

HOUSING:

- Rugged, 26 gauge, galvanized steel construction
- Polymeric, 4" round duct connector with tapered sleeve and no metallic clatter
- 7-5/8" height allows for 2" x 8" (nominal) joist installations
- Sturdy, easy, four-point mounting directly to joist
- Includes unique spacer (patent pending) for mounting to engineered "I" joists
- Includes hanger bars to position housing anywhere between 16" to 24"-on-center joists
- Two sets of mounting holes for hanger bars allow flush installation with bottom or top of drywall
- Can be mounted in ceilings up to 12/12 pitch

GRILLE:

- Polymeric construction
- Innovative design - the result of extensive research with designers and consumers

CONTROLS (Purchase separately):

- Refer to NuTone's catalog for a complete line of accessories to effectively adapt these fans to your construction requirements.

U.L. Listed for use over bathtubs and showers when connected to a GFCI protected branch circuit (ceiling mount only).

3-Year Warranty



INSTALLATION

Complete installation instructions are included with each Fan.

QTREN

Series Fans

MODELS QTREN080, QTREN110

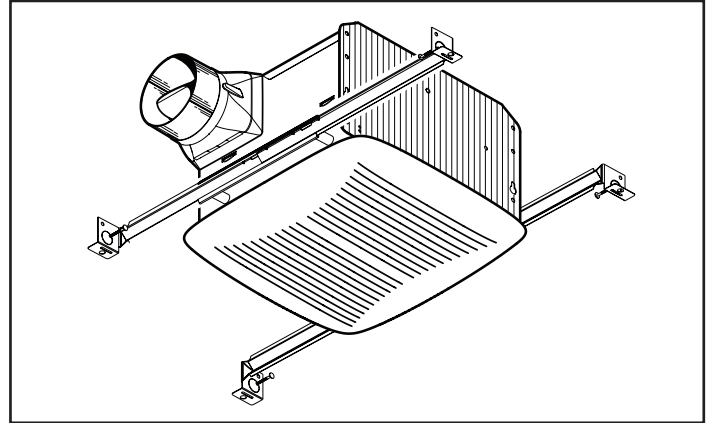

ARCHITECT'S SPECIFICATION

- Ceiling Ventilator shall be NuTone Model QTREN080 (QTREN110).
- Ceiling Ventilator shall have corrosion resistant galvanized steel housing with four-point mounting capability. It shall be ducted to a roof or wall cap using 4" round ductwork.
- Blower assembly shall be removable, have a centrifugal-type blower wheel and a permanently lubricated motor designed for continuous operation and mounted with resilient anti-vibration mounts.
- Non-metallic damper/duct connector shall be included.
- Air delivery shall be no less than 80 (110) CFM and sound level no greater than 0.8 (1.3) Sones. All air and sound ratings shall be certified by HVI.
- Ceiling ventilator shall be Energy Star® qualified and have an energy efficient permanent split capacitor motor.
- Ceiling Ventilator shall be U.L. Listed for use over bathtubs and showers when connected to a GFCI protected branch circuit.

Broan-NuTone LLC Hartford, Wisconsin www.nutone.com 888-336-3948

REFERENCE	QTY.	REMARKS	Project
			Location
			Architect
			Engineer
			Contractor
			Submitted by Date

PERFORMANCE RATINGS QTREN SERIES FANS

HVI PERFORMANCE

Model	Sones @0.1" Ps	CFM @0.1" Ps
QTREN080	0.8	80
QTREN110	1.3	110



HVI-2100 CERTIFIED RATINGS comply with new testing technologies and procedures prescribed by the Home Ventilating Institute, for off-the-shelf products, as they are available to consumers. Product performance is rated at 0.1 in. static pressure, based on tests conducted in AMCA's state-of-the-art test laboratory. Sones are a measure of humanly-perceived loudness, based on laboratory measurements.

AMPS

Model	Amps
QTREN080	0.4
QTREN110	0.4

WEIGHT

Model	Shipping Weight
QTREN080	12.0 lbs.
QTREN110	12.0 lbs

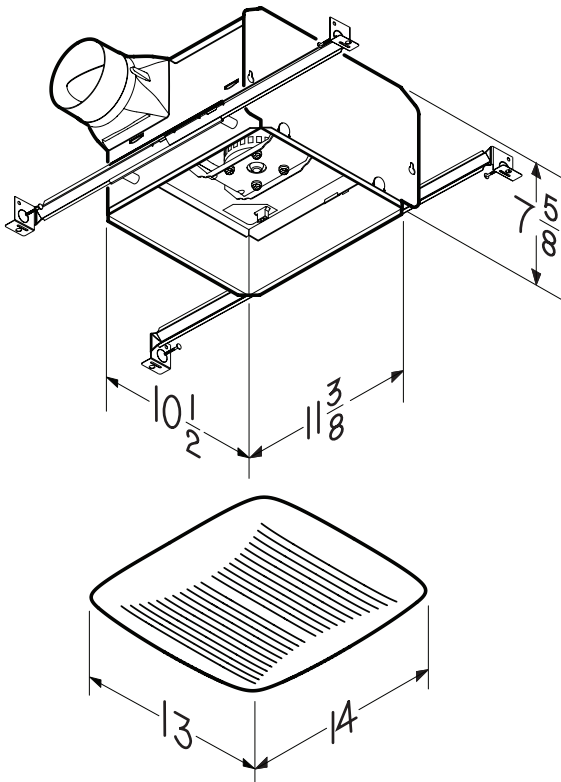

AIR FLOW PERFORMANCE

MODEL QTREN080

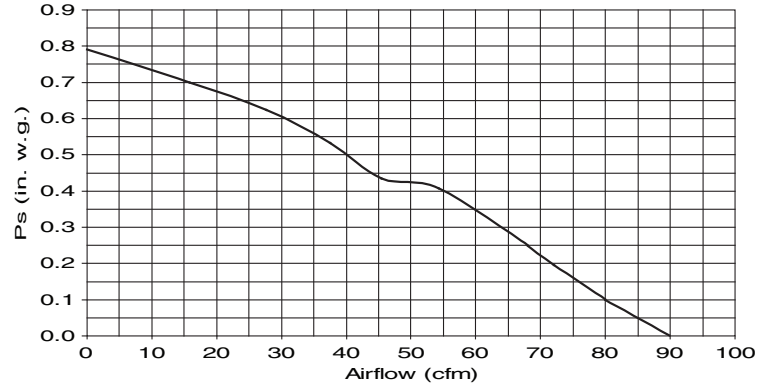

MODEL QTREN110

